

# Underground Belt Structure

Flex PAL™ Series (CEMA C & D)





## Interchangeable

The new Cat® Flex PAL™ Series is designed to work seamlessly with existing underground bulk-material conveyor systems. The retrofit design allows for easy integration with major competitive underground structure configurations. With a wide range of product compatibility, the Flex PAL™ series makes upgrading equipment effortless. Triple-tested with a standard three-years-to-life warranty, Flex PAL™ offers quality and performance assurance for your mining operations unsurpassed in the industry.

### Roof-Hung Structure

This typical 10-foot section of roof-hung structure features the Cat handle and pin rail connections for quick installation. No special tools are required to set up.

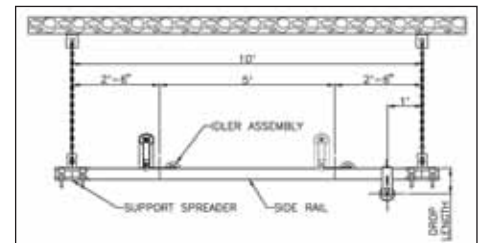

### Floor-Mounted Structure

The example of floor-mounted handle & pin structure shows the return rolls mounted in drop brackets attached to the channel rails. Return rolls can also be mounted in the floor stands.

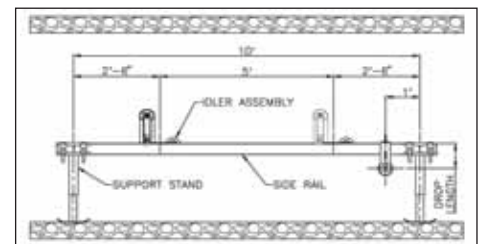

### Wire-Rope Structure

The Cat wire-rope structure features carrying idlers with mounting feet that cradle the wire rope until securely fastened with the supplied hardware. The tie-off stands can be floor-mounted or roof-hung, as shown on page 7 of this brochure.

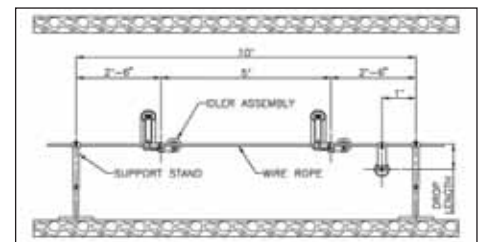

# Cat® Carrying Assemblies

Cat carrying idlers have a single mechanical tube crossmember, sized to handle full capacity loading through 60 in belt widths. Box frame carrying idlers are also available.

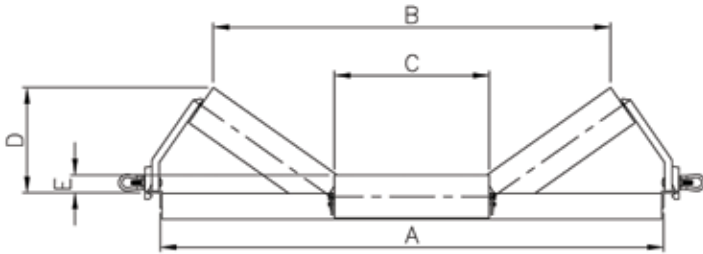

Cat® steel rolls going through an automated five-stage assembly and testing process.

## Carrying Idler Assemblies for Channel Mount

### 4 inø - 35° - 7Ga. - CEMA C or D Carrying Assembly\*

Belt Width	Part No.		A	B	C	D	E
	CEMA C	CEMA D					
30	865813	—	41 ft 1/4 in	31 ft 5/16 in	12 ft 1/4 in	8 ft 3/4 in	1 ft 7/8 in
36	865814	—	47 ft 1/4 in	35 ft 13/16 in	14 ft 1/4 in	10 ft 5/16 in	1 ft 7/8 in
42	865815	—	53 ft 1/4 in	42 ft 11/16 in	16 ft 1/4 in	10 ft 9/16 in	1 ft 7/8 in

### 5 inø - 35° - 7Ga. - CEMA C or D Carrying Assembly\*

Belt Width	Part No.		A	B	C	D	E
	CEMA C	CEMA D					
36	865816	—	47 ft 1/4 in	35 ft 3/16 in	14 ft 1/4 in	10 ft 3/4 in	2 ft 3/8 in
42	865770	865823	53 ft 1/4 in	42 ft 1/8 in	16 ft 1/4 in	11 ft	2 ft 3/8 in
48	865736	865824	59 ft 1/4 in	46 ft 11/16 in	18 ft 1/4 in	12 ft 1/4 in	2 ft 1/16 in
54	865817	865825	65 ft 1/4 in	51 ft 15/16 in	20 ft 1/4 in	13 ft 3/8 in	2 ft 1/16 in

### 6 inø - 35° - 7Ga. - CEMA C or D Carrying Assembly\*

Belt Width	Part No.		A	B	C	D	E
	CEMA C	CEMA D					
36	865818	—	47 ft 1/4 in	34 ft 9/16 in	14 ft 1/4 in	11 ft 1/8 in	2 ft 7/8 in
42	865819	865826	53 ft 1/4 in	41 ft 5/8 in	16 ft 1/4 in	11 ft 7/16 in	2 ft 7/8 in
48	865820	865827	59 ft 1/4 in	46 ft 1/8 in	18 ft 1/4 in	12 ft 5/8 in	2 ft 9/16 in
54	865821	865828	65 ft 1/4 in	51 ft 3/8 in	20 ft 1/4 in	13 ft 13/16 in	2 ft 9/16 in
60	865822	865829	71 ft 1/4 in	56 ft 5/8 in	20 ft 1/4 in	14 ft 15/16 in	2 ft 9/16 in

\*Available with 1/4 in wall rolls upon request.

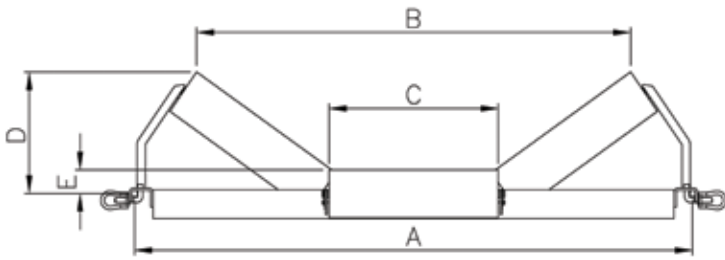

Carrying idler for channel structure

## Carrying Idler Assemblies for Wire-Rope Mount

### 4 in $\varnothing$ - 35° - 7Ga. - CEMA C or D Carrying Assembly\*

Belt Width	Part No.		A	B	C	D	E
	CEMA C	CEMA D					
30	865831	—	42 in	31 ft 5/16 in	12 ft 1/4 in	9 ft 1/8 in	2 ft 1/4 in
36	865832	—	48 in	35 ft 13/16 in	14 ft 1/4 in	10 ft 11/16 in	2 ft 1/4 in
42	865833	—	54 in	42 ft 11/16 in	16 ft 1/4 in	10 ft 15/16 in	2 ft 1/4 in

### 5 in $\varnothing$ - 35° - 7Ga. - CEMA C or D Carrying Assembly\*

Belt Width	Part No.		A	B	C	D	E
	CEMA C	CEMA D					
36	865834	—	48 in	35 ft 3/16 in	14 ft 1/4 in	11 ft 1/8 in	2 ft 3/4 in
42	865835	865843	54 in	42 ft 1/8 in	16 ft 1/4 in	11 ft 3/8 in	2 ft 3/4 in
48	865836	865844	60 in	46 ft 11/16 in	18 ft 1/4 in	12 ft 5/8 in	2 ft 7/16 in
54	865837	865845	66 in	51 ft 15/16 in	20 ft 1/4 in	13 ft 3/4 in	2 ft 7/16 in

### 6 in $\varnothing$ - 35° - 7Ga. - CEMA C or D Carrying Assembly\*

Belt Width	Part No.		A	B	C	D	E
	CEMA C	CEMA D					
36	865838	—	48 in	34 ft 9/16 in	14 ft 1/4 in	11 ft 1/2 in	3 ft 1/4 in
42	865839	865846	54 in	41 ft 5/8 in	16 ft 1/4 in	11 ft 13/16 in	3 ft 1/4 in
48	865840	865847	60 in	46 ft 1/8 in	18 ft 1/4 in	13 ft	2 ft 15/16 in
54	865841	865848	66 in	51 ft 3/8 in	20 ft 1/4 in	14 ft 3/16 in	2 ft 15/16 in
60	865842	865849	72 in	56 ft 5/8 in	22 ft 1/4 in	15 ft 5/16 in	2 ft 15/16 in

\*Available with 1/4 in wall rolls upon request.

# Cat EXALON™ Rolls

## Another perfect choice for underground mining operations

In addition to our world-class steel rolls, Caterpillar offers a highly successful range of CEMA C-, D- and E-class rolls made of a proprietary high molecular weight polyethylene (HMWPE) called EXALON™.

While steel rolls are effective in most bulk-material handling applications, some applications benefit from the use of the EXALON™ roll product. Applications with environments that are highly corrosive, abrasive, wet or have a tendency for material buildup on the roller are ideal for the EXALON™ roll and its additional features and benefits.

### Flex PAL™ Center EXALON™ Design Features:

- Center roll subject to most frequent replacement – most wear of the three rolls
- Helps reduce the frequency of replacing the center idler roll with EXALON™
- The EXALON™ roll's shell life can be two to three times longer than a steel roll's

### Smooth operators

Tube-based with higher concentricity further enhanced by final machining (poly-body) for reduced belt wear, the EXALON™ roll offers balanced, vibration-free running. These fully conductive rolls are MSHA-certified as safe for underground use. They have two certifications: IC-56/1 – flame-resistant and IC-56/2 – flame-resistant and static-dissipating.

### Versatile, low-maintenance

EXALON™ rolls can be retrofitted to any frame – even those of competitors. Custom sizes can be ordered for special applications. EXALON™ heads are installed using a unique “spin-welding” method, creating a single-piece roll construction. Cat Idler PAL™ (Positive Automatic Lubrication) ensures life-long grease management, making them virtually maintenance-free.

### Tested for quality

All Cat rolls – EXALON™ and steel – are processed through an automated assembly system that tests and records rotational torque, total indicator run-out and axial end play. Upon acceptance, each idler roll is permanently marked with a serial number and date of manufacture.



## EXALON™ Benefits at a Glance

### MSHA certified

Certified for underground use: IC-56/1 – flame resistant and IC-56/2 – flame resistant and static dissipating.

### Longer shell life

EXALON™ rolls last two to three times longer than steel rolls in highly corrosive and/or highly abrasive environments.

### Low maintenance

Cat Idler PAL™ ensures life-long grease management.

### Reduced belt damage

The smooth PE surface minimizes belt friction and wear and acts as a slider bar in the event of a bearing seizure. The all-PE body means there are no sharp ‘pizza cutter’ edges.

### Lighter weight

EXALON™ rolls are 20-30% lighter than equivalent steel rolls.

### Corrosion-proof

Being made of HMWPE, the EXALON™ roll is not subject to corrosion.

### Sound dampening

Reduce noise by up to 20%, particularly in underground applications.

### Resistance to material buildup

The smooth, non-adhesive HMWPE surface resists material buildup.

### Cost-efficient

EXALON™ offers cost savings through extended life, reduced downtime, longer replacement intervals and reduced belt damage.

### Versatile

The entire EXALON™ product line can be produced to fit any existing manufacturer's top-side and return frame assemblies.

## Handle & Pin Roof-Hung Spreader Assemblies

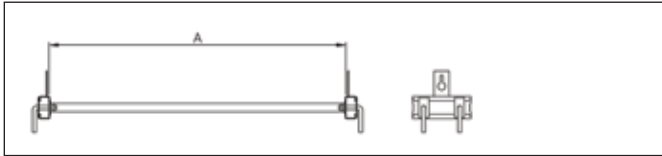

### 3 in Channel Spreader

Belt Width	Part No.	A
30	603895	41 ft 1/4 in
36	603896	47 ft 1/4 in
42	603897	53 ft 1/4 in

### 4 in Channel Spreader

Belt Width	Part No.	A
42	603898	53 ft 1/4 in
48	603899	59 ft 1/4 in
54	865739	65 ft 1/4 in
60	865740	71 ft 1/4 in

## Handle & Pin Side Rails

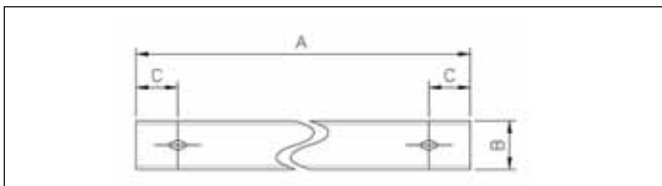

### 3 in Channel Rail

Part No.	A	B	C
865851	7 ft-11 ft 3/4 in	3 in	3 ft 7/16 in
603890	9 ft-11 ft 3/4 in	3 in	3 ft 7/16 in
865852	11 ft-11 ft 3/4 in	3 in	3 ft 7/16 in

### 4 in Channel Rail

Part No.	A	B	C
865853	7 ft-11 ft 3/4 in	4 in	3 ft 7/16 in
603677	9 ft-11 ft 3/4 in	4 in	3 ft 7/16 in
865854	11 ft-11 ft 3/4 in	4 in	3 ft 7/16 in

## Handle & Pin Adjustable Floor Stand Assemblies

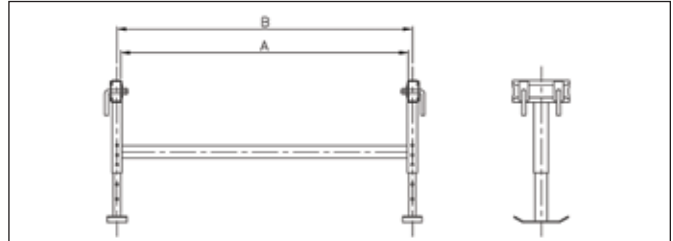

### 3 in Channel Floor Stand

Belt Width	Part No.	A	B
30	865914	41 ft 1/4 in	42 ft 5/8 in
36	865915	47 ft 1/4 in	48 ft 5/8 in
42	865916	53 ft 1/4 in	54 ft 5/8 in

### 4 in Channel Floor Stand

Belt Width	Part No.	A	B
42	865917	53 ft 1/4 in	54 ft 5/8 in
48	865918	59 ft 1/4 in	60 ft 5/8 in
54	865919	65 ft 1/4 in	66 ft 5/8 in
60	865920	71 ft 1/4 in	72 ft 5/8 in

## Channel Slider/Hanger Brackets

### Slider/Hanger Brackets

Part No.	Channel Size
603556	3 in CHANNEL
603557	4 in CHANNEL

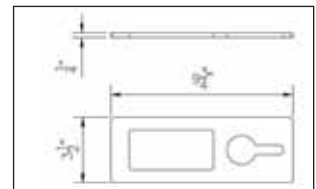

## Roof Mounting Plates for Chain Hung Structure

### Roof Plates

Part No.	A
223140	3/4 in
246787	1 in
213551	1 ft 1/4 in
242648	1 ft 1/2 in

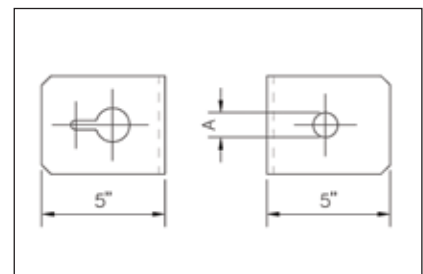

## Return Roll Assemblies

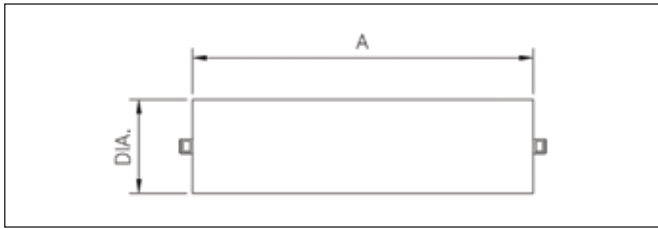

### 4 inø - 7Ga. Return Roll\*

Belt Width	Part No.		A
	CEMA C	CEMA D	
30	326506	—	39 in
36	326507	—	45 in
42	326508	—	51 in

### 5 inø - 7Ga. Return Roll\*

Belt Width	Part No.		A
	CEMA C	CEMA D	
36	326563	326665	45 in
42	326564	326666	51 in
48	326565	326668	57 in
54	326566	326669	63 in

### 6 inø - 7Ga. Return Roll\*

Belt Width	Part No.		A
	CEMA C	CEMA D	
36	326609	326780	45 in
42	326611	326781	51 in
48	326612	326782	57 in
54	326613	326783	63 in
60	326614	326784	69 in

\*Available with 1/4 in wall rolls upon request.

## Wire-Rope Adjustable Tie-Off Assemblies

### Tie-Off Stands

Part No.	A Min.	A Max.
276956	24 in	36 in
271136	32 in	48 in

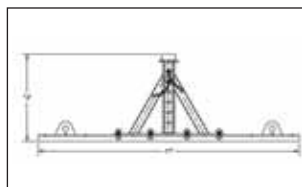

## Cat Standard Chain

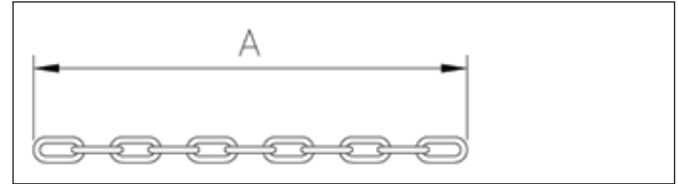

### 1/4 Proof Coil Chain with Hook

Part No.	A
208650	4 ft
244458	5 ft
231598	6 ft

### 5/16 Proof Coil Chain without Hook

Part No.	A
222516	5 ft
216997	6 ft

## Channel Mounted Drop Brackets

### 3 in Brackets

Part No.	A
865670	9 in
865855	12 in
865856	16 in

### 4 in Brackets

Part No.	A
865671	9 in
865857	12 in
865858	16 in

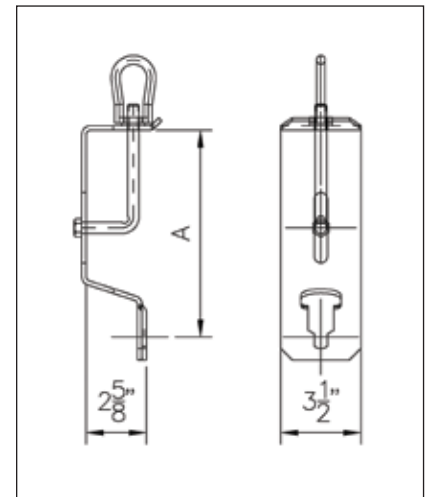

## Wire Rope Drop Brackets

### 3 in Brackets

Part No.	A
884029	9 in
865911	12.75 in
865912	16.5 in

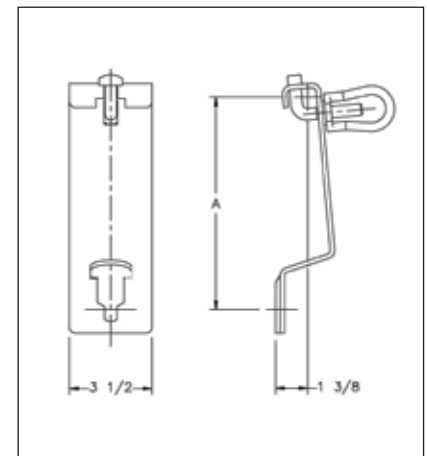

# Underground Belt Structure – Flex Pal™ Series (CEMA C & D)

For more complete information on Cat products, dealer services, and industry solutions, visit us on the web at [mining.cat.com](http://mining.cat.com) and [www.cat.com](http://www.cat.com)

© 2011 Caterpillar Inc.  
All rights reserved

AEXQ0593

Materials and specifications are subject to change without notice. Featured machines in photos may include additional equipment. See your Cat dealer for available options.

CAT, CATERPILLAR, their respective logos, "Caterpillar Yellow" and the "Power Edge" trade dress, as well as corporate and product identity used herein, are trademarks of Caterpillar and may not be used without permission.

